

XOPSTWR

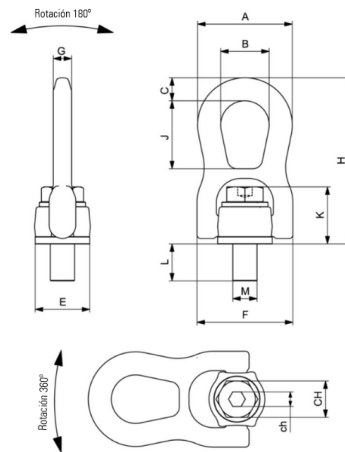

Description Anneau de levage émerillon.

- Caractéristiques**
- Rotation à 360° ; s'oriente en fonction de la direction de traction.
 - Anneau pour charge basculante.
 - Capacité de charge maximale dans toutes les directions.

Conforme à • Norme EN1677-4

Referencia	Rosca [M]	CMU [t]	Peso [kg]	A [mm]	B [mm]	C [mm]	E [mm]	F [mm]	G [mm]	H [mm]	J [mm]	K [mm]	L [mm]	CH [mm]	ch [mm]
XOPSTWR-08	M08	0.3	0.37	56	28	14	30	55	11	99	40	33.5	12	13	5
XOPSTWR-10	M10	0.6	0.37	56	28	14	30	55	11	99	40	34.5	15	17	6
XOPSTWR-12	M12	1	0.37	56	28	14	30	55	11	99	40	35.5	18	19	7
XOPSTWR-14	M14	1.3	1.3	74.5	38	18	47	78	17	135.5	55	46	21	22	7
XOPSTWR-16	M16	1.6	1.3	74.5	38	18	47	78	17	135.5	55	46.5	25	24	10
XOPSTWR-18	M18	2	1.3	74.5	38	18	47	78	17	135.5	55	47	27	27	10
XOPSTWR-20	M20	2.5	1.3	74.5	38	18	47	78	17	135.5	55	48	30	30	12
XOPSTWR-22	M22	3	4	106	56	25	62	114.5	22	198.5	84	63.5	33	32	12
XOPSTWR-24	M24	4	4	106	56	25	62	114.5	22	198.5	84	64.5	36	36	14
XOPSTWR-30	M30	6.3	4	106	56	25	62	114.5	22	198.5	84	68	45	46	17

EN1677-4

SpanSet SARL

Tél. 04 72 47 69 90

Fax. 04 72 47 00 19

Email commercial@spanset.fr

www.spanset.fr

