

## Ratchet tensioner EXOSET® with shortening hook G100

Ratchet tensioner with shortening hook and unscrewing lock



Item Name short	Chain Diameter	Dimension A [mm]	Dimension H [mm]	Dimension L1 max [m]	Dimension L1 min [m]	Dimension P [mm]	Lashing Capacity [daN]
RTGH-8-10	8 mm	50	98	500	340	56	5000
RTGH-10-10	10 mm	50	122	525	365	65	8000
RTGH-13-10	13 mm	72	160	525	365	69	13400

Item Name short	Lever Length Y [mm]	Standard Tension Force [daN]	Weight Net [kg]
RTGH-8-10	383	2300	3.7
RTGH-10-10	390	2800	5.9
RTGH-13-10	393	3600	9.4

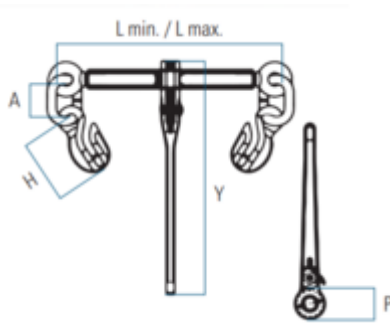

### ORDER NUMBERS

Chain Diameter	RTGH-8-10	RTGH-10-10	RTGH-13-10
419	2009053	-	-
420	-	2009054	-
421	-	-	2009055

- Norms EN 12195-3
- Grade 100
- Colour Blue
- Main Material Steel
- Temperature Range -30° C to + 100° C

## Ratchet tensioner with secured parallel hooks

Subject to technical changes. All rights reserved. No part of this Technical Data Sheet may be reproduced in any form (print, photocopy, microfilm or any other process) or processed, duplicated or distributed using electronic systems without the written permission of SpanSet. This Technical Data Sheet has been prepared with due care; SpanSet accepts no liability for errors or omissions. © SpanSet (UK) Limited - United Kingdom

