

Product number: IN-2197

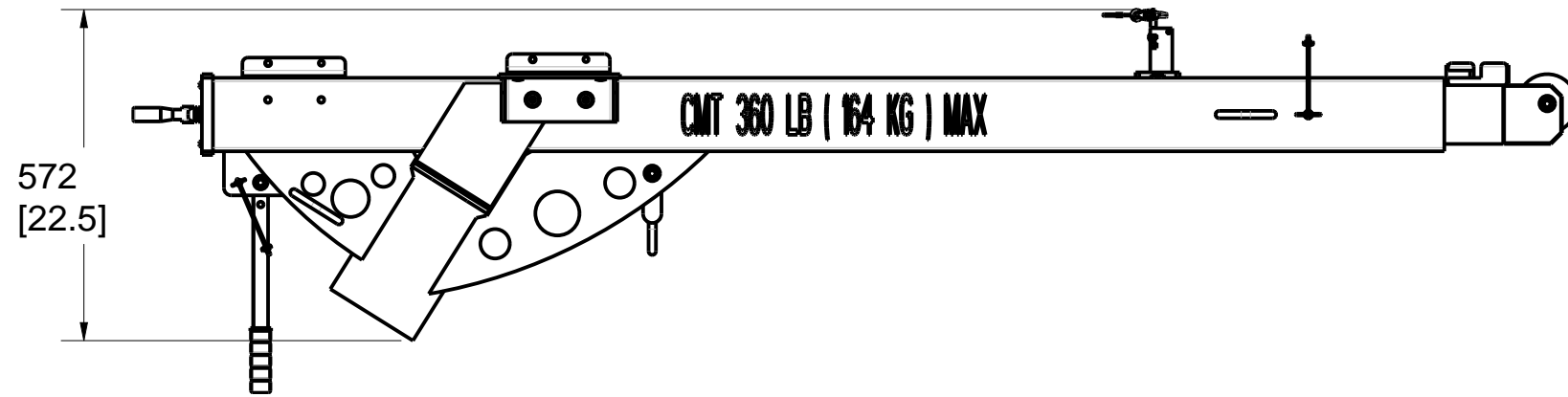

PAT. NO.:		©06/04/2010 ©	
<p align="center"><b>PRODUITS DE SERVICE PUBLICS INNOVA INC.</b> <b>INNOVA PUBLIC UTILITY PRODUCTS INC.</b></p>			
<p align="center"><small>© 9105-0732 QUEBEC INC. and under exclusive license to INNOVA PUBLIC UTILITY PRODUCTS INC., (hereafter « INNOVA »). All rights reserved. Protected under the Copyright Act of Canada and international treaties and agreements regarding copyrights. Violators are subject to prosecution and other legal recourses for infringement. Any reproduction, adaptation or other use or disclosure whatsoever, in totality or in part, and in any form or by any means whatsoever, strictly forbidden and requires the prior written approval of INNOVA. All data is the exclusive property of 9105-0732 QUEBEC INC. and under exclusive license to INNOVA and cannot be used nor disclosed in any way either without the prior written approval of INNOVA.</small></p>			
WEIGHT:	TITLE:		
140 Lb	Extendable davit arm		
64 Kg	1524mm-2438mm (60"-96")		
COLOR:	MATERIAL:	SHEET(S):	PROJECT:
Yellow security	Aluminum	1 / 4	IN-2197

Product number: IN-2197

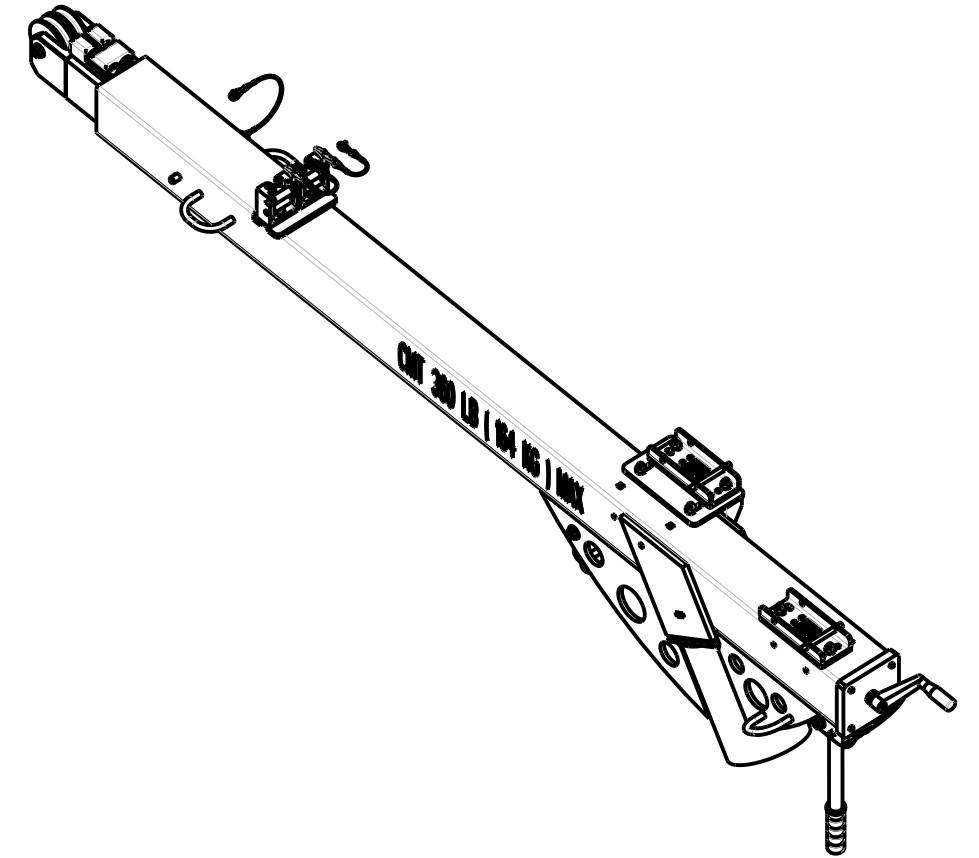
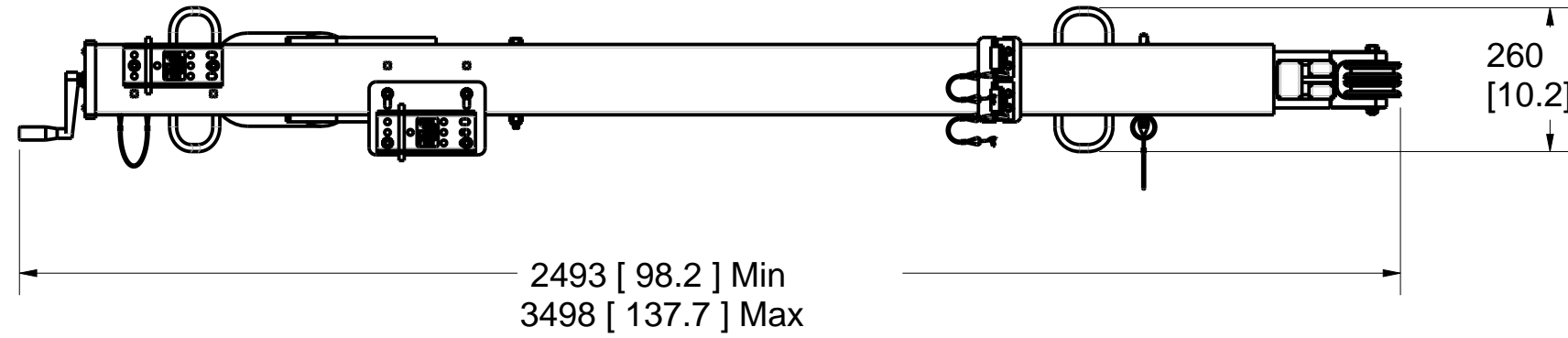
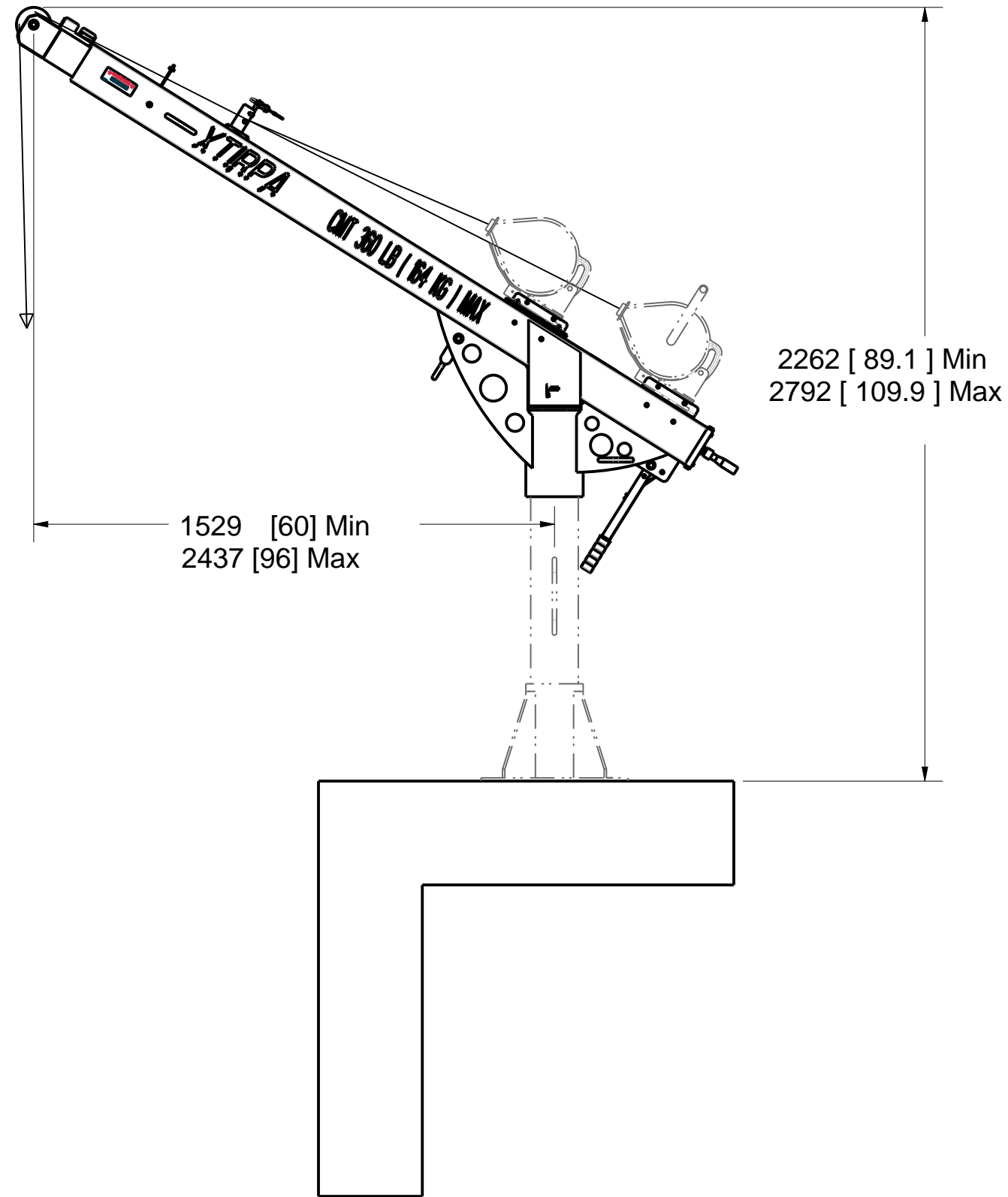

PAT. NO.:		©06/04/2010	©
<b>PRODUITS DE SERVICE PUBLICS INNOVA INC.</b> <b>INNOVA PUBLIC UTILITY PRODUCTS INC.</b>			
<small>© 9105-0732 QUEBEC INC. and under exclusive license to INNOVA PUBLIC UTILITY PRODUCTS INC., (hereafter « INNOVA »). All rights reserved. Protected under the Copyright Act of Canada and international treaties and agreements regarding copyrights. Violators are subject to prosecution and other legal recourses for infringement. Any reproduction, adaptation or other use or disclosure whatsoever, in totality or in part, and in any form or by any means whatsoever, strictly forbidden and requires the prior written approval of INNOVA. All data is the exclusive property of 9105-0732 QUEBEC INC. and under exclusive license to INNOVA and cannot be used nor disclosed in any way either without the prior written approval of INNOVA.</small>			
WEIGHT:	TITLE:		
140 Lb	Extendable davit arm		
64 Kg	1524mm-2438mm (60"-96")		
COLOR:	MATERIAL:	SHEET(S):	PROJECT:
Yellow security	Aluminum	2 / 4	IN-2197

Product number: IN-2197

**SPECIFICATIONS**

H This equipment is considered as part of a personal fall arrest system (PFAS) with a maximum working capacity of 164 Kg (360 lb). It is only to be used in conjunction with a personal fall arrest system that limits the maximum arrest force (MAF).

G Working load (masse):  
 With lifeline winch or material handling winch in position 1 or 2 :  
 With mast IN-2199 : 164 Kg ( 360 lb)

F Max design capacity with lifeline winch or material handling winch Position 1 or 2 :  
 With mast IN-2199 : 16,014 N ( 3,600 lbf )

Max capacity of anchor point: 22,241 N ( 5,000 lbf )

**STANDARDS**

E Meets the following standards:  
 OSHA Personal fall arrest system - 1910.66 App C  
 ANSI Safety requirements for personal fall arrest system, subsystems and components Z359.1 ( R1999 ) / 2007  
 CAN/CSA Fall arresters, vertical lifelines, and rails Z259.2.1-98

**MATERIAL AND CONSTRUCTION**

D Extension and guide tubes: Aluminum 6061-T6  
 Anchorage hooks: 304 stainless steel  
 Hardware: Zinc plated steel  
 Guide tube sliders: UHMW  
 Pulley: Black delrin acetal  
 Finish: Yellow security powder point with metal protection base.  
 C Welding Certification: CSA W47.2M and CSA W47.1

**RESTRICTIONS**

B This product is to be used only with products approved by Innova Public Utility Products inc.

**IMPORTANT :**

A Periodic inspections of hardware must be done. In the occurrence of a fall or the safety of the equipment is in doubt, equipment must be immediately removed from service and inspected by qualified personnel before reuse.

\*\* This equipment must always be operated in a level position.

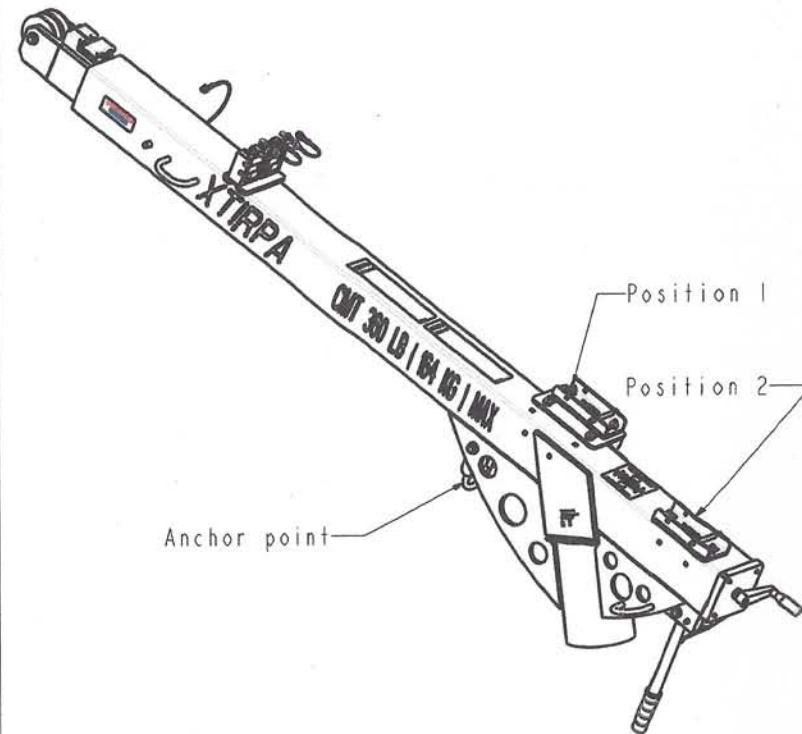

PAT. NO. :		006/04/2010 ©	
PRODUITS DE SERVICE PUBLICS INNOVA INC. INNOVA PUBLIC UTILITY PRODUCTS INC.			
© 9105-0792 QUEBEC INC. and under exclusive license to INNOVA PUBLIC UTILITY PRODUCTS INC., tous droits réservés. Protégé sous le Copyright Act of Canada and international treaties and agreements regarding copyrights. Violators are subject to prosecution and other legal recourse for infringement. Any reproduction, adaptation or other use or disclosure whenever, in total or in part, and in any form or by any means whatsoever, strictly forbidden and requires the prior written approval of INNOVA. All data is the exclusive property of 9105-0792 QUEBEC INC. and under exclusive license to INNOVA and cannot be used nor disclosed in any way either without the prior written approval of INNOVA.			
WEIGHT:	TITLE:		
140 Lb	Extendable davit arm		
64 Kg	1524mm-2438mm (60"-96")		
COLOR:	MATERIAL:	SHEET(S):	PROJECT:
Yellow security	Aluminum	3 / 4	IN-2197

8

7

6

5

4

3

2

1

Product number: IN-2197

IDX	QTE	COMPONENT	REV	DESCRIPTION
8	1	S2197-002	RevD	Label Instruction English
7	1	S2197-001	RevD	Label Instruction French
6	1	S2197-006	RevB	Label "Attention" French
5	1	S2197-007	revA	Label "Warning" English
4	1	S2197-004	RevA	Label "Warning" English
3	1	S2197-003	RevA	Label "Attention" French
2	2	S2198-003	04	Label Maximum Load
1	2	S2002-003	02	Label XTIRPA 3-1/2" x 11-3/4"

H  
G  
F  
E  
D  
C  
B  
A

H  
G  
F  
E  
D  
C  
B  
A

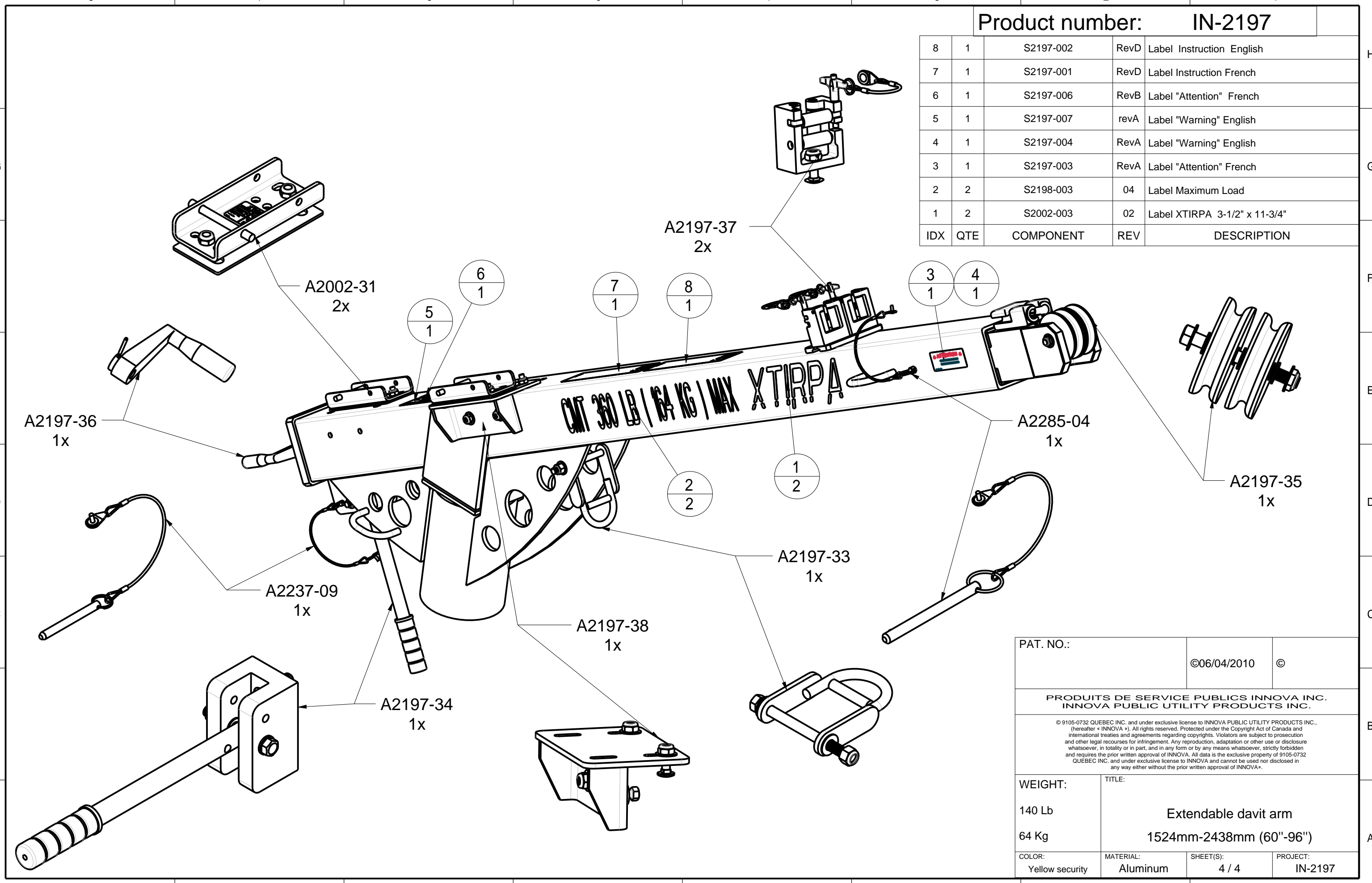

PAT. NO.:		©06/04/2010	©
PRODUITS DE SERVICE PUBLICS INNOVA INC. INNOVA PUBLIC UTILITY PRODUCTS INC.			
<small>© 9105-0732 QUEBEC INC. and under exclusive license to INNOVA PUBLIC UTILITY PRODUCTS INC., (hereafter « INNOVA »). All rights reserved. Protected under the Copyright Act of Canada and international treaties and agreements regarding copyrights. Violators are subject to prosecution and other legal recourses for infringement. Any reproduction, adaptation or other use or disclosure whatsoever, in totality or in part, and in any form or by any means whatsoever, strictly forbidden and requires the prior written approval of INNOVA. All data is the exclusive property of 9105-0732 QUEBEC INC. and under exclusive license to INNOVA and cannot be used nor disclosed in any way either without the prior written approval of INNOVA.</small>			
WEIGHT:	TITLE:		
140 Lb	Extendable davit arm		
64 Kg	1524mm-2438mm (60"-96")		
COLOR:	MATERIAL:	SHEET(S):	PROJECT:
Yellow security	Aluminum	4 / 4	IN-2197

8

7

6

5

4

3

2

1