

PAT. NO.:		©16/03/2011	©
PRODUITS DE SERVICE PUBLICS INNOVA INC. INNOVA PUBLIC UTILITY PRODUCTS INC.			
<small>© 9105-0732 QUEBEC INC. and under exclusive license to INNOVA PUBLIC UTILITY PRODUCTS INC., (hereafter « INNOVA »). All rights reserved. Protected under the Copyright Act of Canada and international treaties and agreements regarding copyrights. Violators are subject to prosecution and other legal recourses for infringement. Any reproduction, adaptation or other use or disclosure whatsoever, in totality or in part, and in any form or by any means whatsoever, strictly forbidden and requires the prior written approval of INNOVA. All data is the exclusive property of 9105-0732 QUEBEC INC. and under exclusive license to INNOVA and cannot be used nor disclosed in any way either without the prior written approval of INNOVA.</small>			
WEIGHT:	TITLE:		
35 Lb	Anchor bolt adapter for hitch mount		
16 Kg			
COLOR:	MATERIAL:	SHEET(S):	PROJECT:
Zinc plated	Steel	1 / 4	A2126-21

Recommendations:

Concrete must be made of 0,2% gross area rebar reinforced 13.8 MPa (2000psi) or better. Minimum thickness of 203mm (8").

Vertical load: 22,241 N (5,000 lbf)
N.B. It is the responsibility of the field engineer to assure the installation and capacity of the floor and wall structures.

Hardware:

Anchor bolt: Chemical setting 3/4" x 6-5/8" effective holding length and made of 304/316 stainless steel.

Max pulling strength: 75,620 N (17,000 lbf)

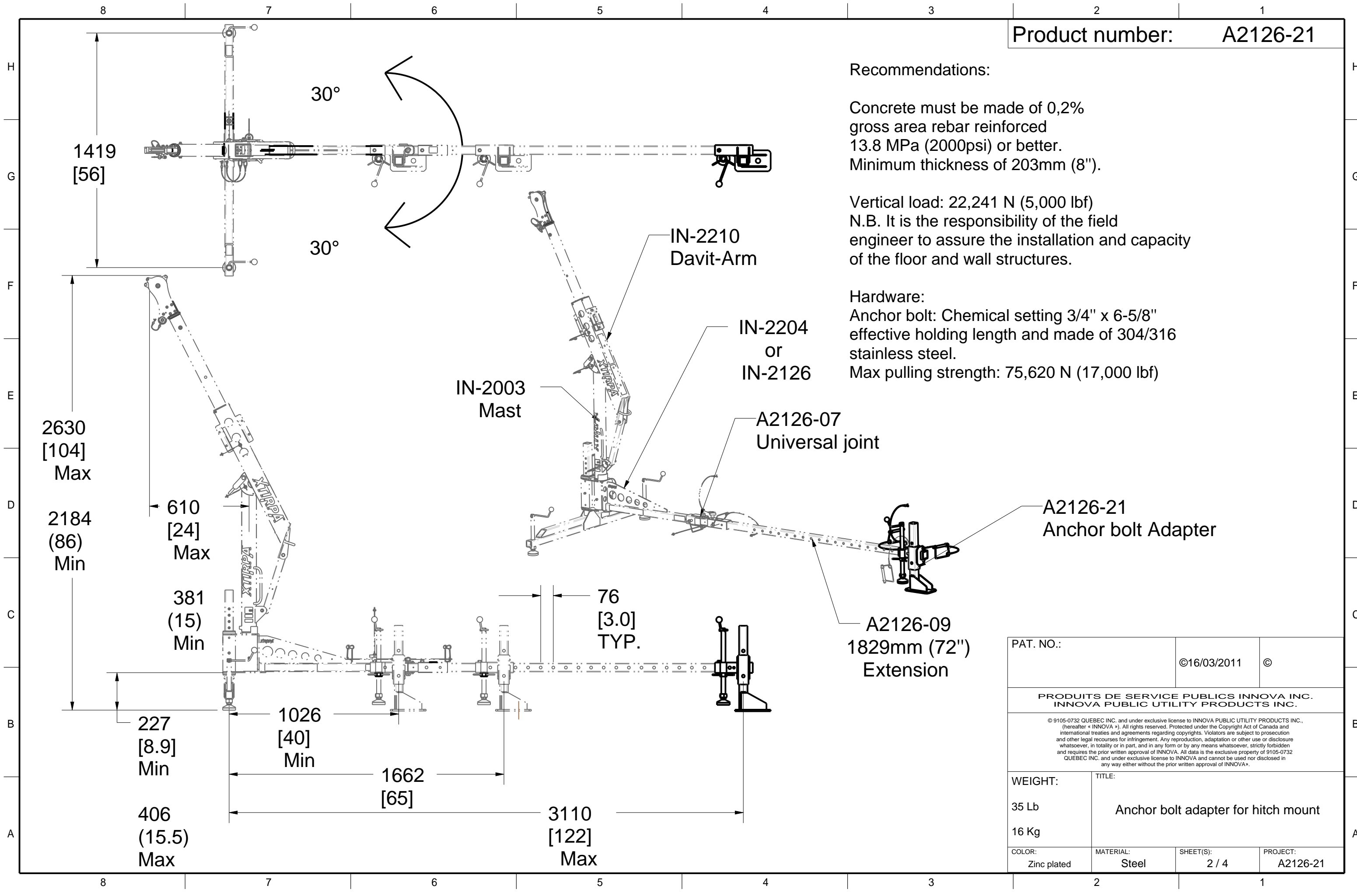

PAT. NO.:		©16/03/2011 ©	
PRODUITS DE SERVICE PUBLICS INNOVA INC. INNOVA PUBLIC UTILITY PRODUCTS INC.			
© 9105-0732 QUEBEC INC. and under exclusive license to INNOVA PUBLIC UTILITY PRODUCTS INC. (hereafter « INNOVA »). All rights reserved. Protected under the Copyright Act of Canada and international treaties and agreements regarding copyrights. Violators are subject to prosecution and other legal recourses for infringement. Any reproduction, adaptation or other use or disclosure whatsoever, in totality or in part, and in any form or by any means whatsoever, strictly forbidden and requires the prior written approval of INNOVA. All data is the exclusive property of 9105-0732 QUEBEC INC. and under exclusive license to INNOVA and cannot be used nor disclosed in any way either without the prior written approval of INNOVA.			
WEIGHT:	TITLE:		
35 Lb 16 Kg	Anchor bolt adapter for hitch mount		
COLOR:	MATERIAL:	SHEET(S):	PROJECT:
Zinc plated	Steel	2 / 4	A2126-21

Product number: A2126-21

SPECIFICATIONS

H This equipment is considered as part of a personal fall arrest system (PFAS).
 It is only to be used in conjunction with a personal fall arrest system that limits the maximum arrest force (MAF).

G Working load limit (WLL): 1,112 N (250 lbf)
 Max design capacity: 11,121 N (2,500 lbf)

Note: The structure must meet the maximum design capacity.

STANDARDS

F Meets the following standards:
 OSHA Personal fall arrest system - 1910.66 App C
 ANSI Safety requirements for personal fall arrest system, subsystems and components Z359.1 (R1999) / 2007
 CAN/CSA Fall arresters, vertical lifelines, and rails Z259.2.1-98
 CE EN 795:1996 + A1:2000 CL. A1

MATERIAL AND CONSTRUCTION

E Body and guide: Zinc plated steel
 Hardware : Zinc plated steel and stainless steel
 Counter Plate : Zinc plated Steel
 Finish : Clear Zinc plated, ASTM B-633-11, Type V, SC3.
 D Welding certification : CSA W59 & 47.1

RESTRICTIONS

IMPORTANT :

c Adapters are designed to function only with Innova Public Utility Products inc. equipment or approved by Innova Public Utility Products

Anchor hardware must be installed by qualified and experienced personnel. The installer must follow the anchor hardware manufacturer's recommendations at all times.

B **The positioning pins must always be in place when in use. Otherwise, serious injuries may occur. Periodic inspections of hardware must be done. In the occurrence of a fall or the safety of the equipment is in doubt, equipment must be immediately removed from service and inspected by qualified personnel before reuse.

A The product is to be use in the load direction only.
 Never use the product with load perpendicular to adapter.

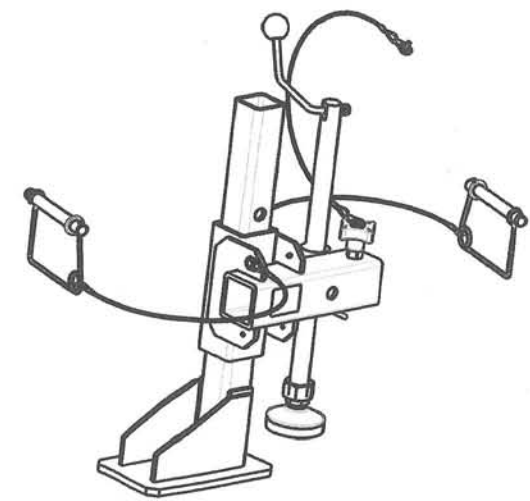

PAT. NO. :		©16/03/2011 ©	
PRODUITS DE SERVICE PUBLICS INNOVA INC. INNOVA PUBLIC UTILITY PRODUCTS INC.			
<small>© 9105-0320 QUEBEC INC. and under exclusive license to INNOVA PUBLIC UTILITY PRODUCTS INC., (hereafter a INNOVA s.r.l. All rights reserved. Protected under the Copyright Act of Canada and International treaties and agreements regarding copyrights. Violators are subject to prosecution and other legal recourse for infringement. Any reproduction, adaptation or other use or disclosure whatsoever, in totality or in part, and in any form or by any means whatsoever, strictly forbidden and requires the prior written approval of INNOVA. All data is the exclusive property of INNOVA-0320 QUEBEC INC. and under exclusive license to INNOVA and cannot be used nor disclosed in any way either without the prior written approval of INNOVA.</small>			
WEIGHT:	TITLE:		
35 Lb	Anchor bolt adapter for hitch mount		
16 Kg	COLOR:	MATERIAL:	SHEETS:
	Zinc plated	Steel	3 / 4
		PROJECT:	A2126-21

Stamping space

Product number: **A2126-21**

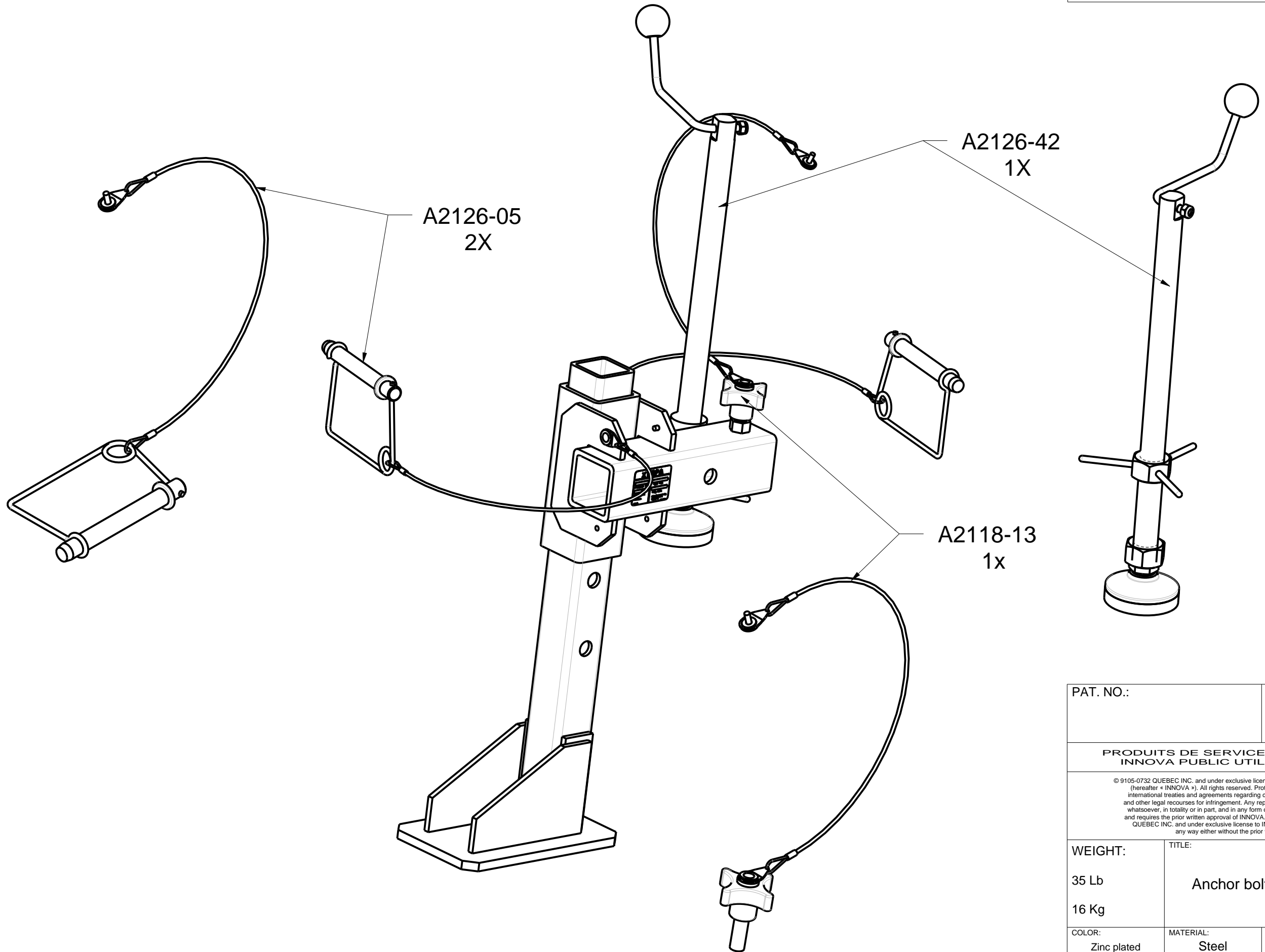

PAT. NO.:		©16/03/2011	©
PRODUITS DE SERVICE PUBLICS INNOVA INC. INNOVA PUBLIC UTILITY PRODUCTS INC.			
<small>© 9105-0732 QUEBEC INC. and under exclusive license to INNOVA PUBLIC UTILITY PRODUCTS INC., (hereafter « INNOVA »). All rights reserved. Protected under the Copyright Act of Canada and international treaties and agreements regarding copyrights. Violators are subject to prosecution and other legal recourses for infringement. Any reproduction, adaptation or other use or disclosure whatsoever, in totality or in part, and in any form or by any means whatsoever, strictly forbidden and requires the prior written approval of INNOVA. All data is the exclusive property of 9105-0732 QUEBEC INC. and under exclusive license to INNOVA and cannot be used nor disclosed in any way either without the prior written approval of INNOVA.</small>			
WEIGHT:	TITLE:		
35 Lb	Anchor bolt adapter for hitch mount		
16 Kg			
COLOR:	MATERIAL:	SHEET(S):	PROJECT:
Zinc plated	Steel	4 / 4	A2126-21